

## Description

The AU0511P1 is a bi-directional TVS diode, utilizing leading monolithic silicon technology to provide fast response time and low ESD clamping voltage, making this device an ideal solution for protecting voltage sensitive data and power line. The AU0511P1 complies with the IEC 61000-4-2 (ESD) standard with  $\pm 15\text{kV}$  air and  $\pm 8\text{kV}$  contact discharge. It is assembled into an ultra-small 1.0x0.6x0.5mm lead-free DFN package. The small size and high ESD surge protection make AU0511P1 an ideal choice to protect cell phone, digital cameras, audio players and many other portable applications.

## Features

- Ultra small package: 1.0x0.6x0.5mm
- Very low capacitance (<5pF)
- Protects one data or power line
- Ultra low leakage: nA level
- Low operating voltage: 5V
- Low clamping voltage
- 2-Pin leadless package
- Complies with following standards:
  - IEC 61000-4-2 (ESD) immunity test  
Air discharge:  $\pm 15\text{kV}$   
Contact discharge:  $\pm 8\text{kV}$
  - IEC61000-4-4 (EFT) 40A (5/50ns)
- RoHS Compliant

## Dimensions and Pin Configuration

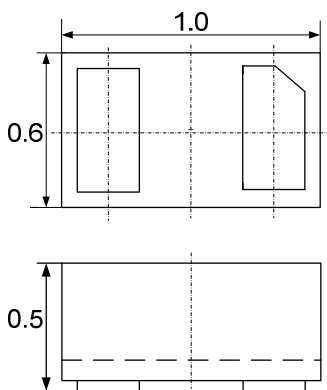

Package Dimensions

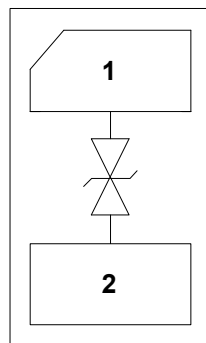

Circuit and Pin Schematic

## Mechanical Characteristics

- Package: DFN1006-2 (1.0x0.6x0.5mm)
- Lead Finish: NiPdAu
- Case Material: "Green" Molding Compound.
- UL Flammability Classification Rating 94V-0
- Moisture Sensitivity: Level 3 per J-STD-020
- Terminal Connections: See Diagram Below
- Marking Information: See Below

## Applications

- Cellular Handsets and Accessories
- Personal Digital Assistants
- Notebooks and Handhelds
- Portable Instrumentation
- Digital Cameras
- Peripherals
- Audio Players
- Keypads, Side Keys, USB 2.0, LCD Displays

## Marking Information



## Ordering Information

Part Number	Packaging	Reel Size
AU0511P1	10000/Tape & Reel	7 inch

**Absolute Maximum Ratings ( $T_A=25^\circ\text{C}$  unless otherwise specified)**

Parameter	Symbol	Value	Unit
ESD per IEC 61000-4-2 (Air)	VESD	$\pm 15$	kV
ESD per IEC 61000-4-2 (Contact)		$\pm 8$	
Operating Temperature Range	TJ	-55 to +125	$^\circ\text{C}$
Storage Temperature Range	Tstg	-55 to +150	$^\circ\text{C}$

**Electrical Characteristics ( $T_A=25^\circ\text{C}$  unless otherwise specified)**

Parameter	Symbol	Min	Typ	Max	Unit	Test Condition
Reverse Working Voltage	VRWM			5	V	Pin 1 to Pin 2 or Pin 2 to Pin 1
Breakdown Voltage	VBR	6	8	9	V	$I_T = 1\text{mA}$ , Pin 1 to Pin 2 or Pin 2 to Pin 1
Reverse Leakage Current	$I_R$			50	nA	VRWM = 5V, Pin 1 to Pin 2 or Pin 2 to Pin 1
Clamping Voltage	VC			11	V	$I_{PP} = 1\text{A}$ (8 x 20 $\mu\text{s}$ pulse), Pin 1 to Pin 2 or Pin 2 to Pin 1
Junction Capacitance	CJ			5	pF	VR = 0V, f = 1MHz

**Typical Performance Characteristics (TA=25°C unless otherwise Specified)**

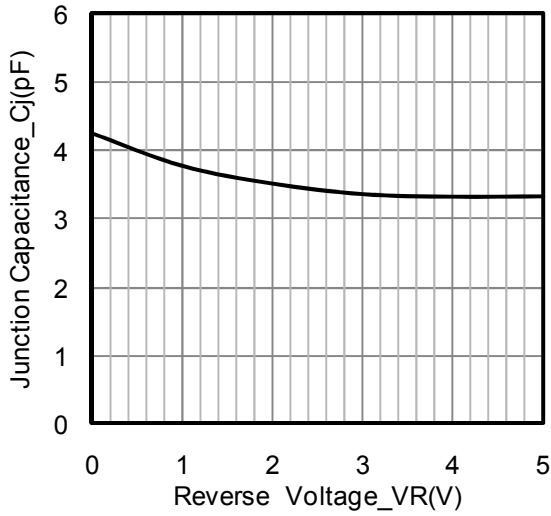

**Junction Capacitance vs. Reverse Voltage**

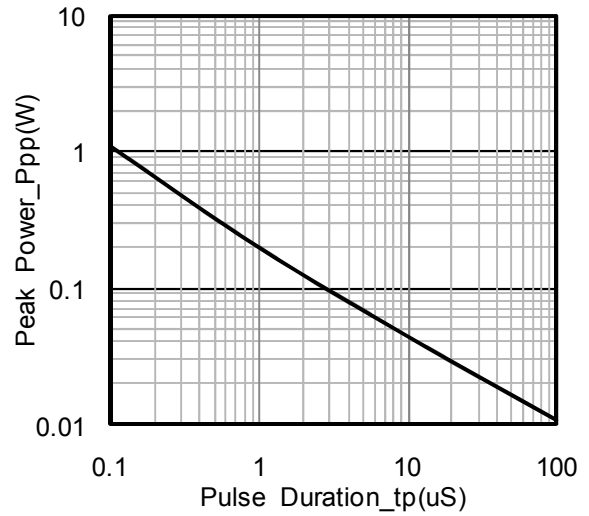

**Peak Pulse Power vs. Pulse Time**

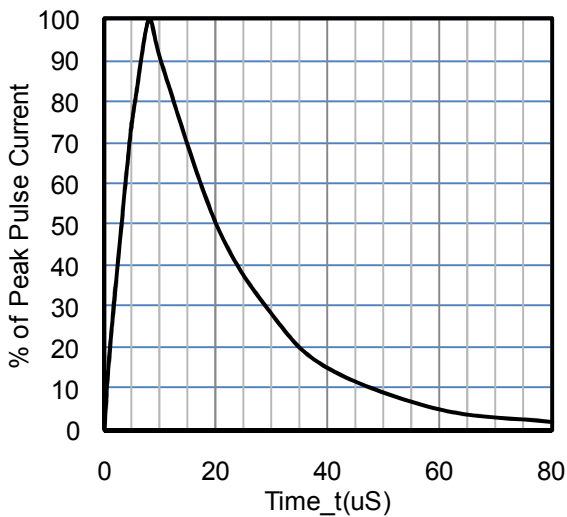

**8 X 20uS Pulse Waveform**

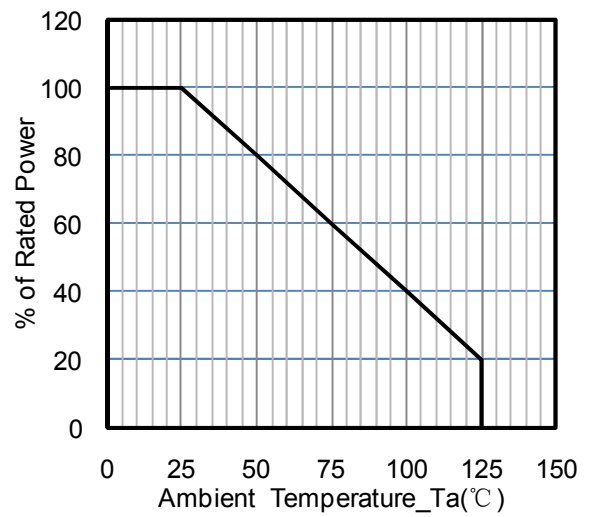

**Power Derating Curve**

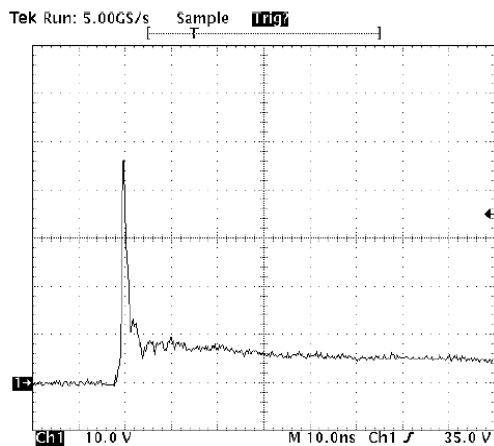

**ESD Clamping Voltage**

**8 kV Contact per IEC61000-4-2**

## DFN1006-2 Package Outline Drawing

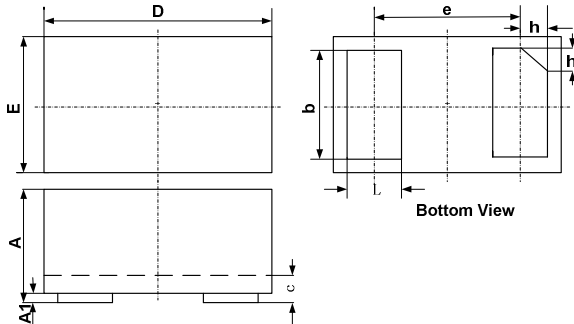

SYM	DIMENSIONS					
	MILLIMETERS			INCHES		
	MIN	NOM	MAX	MIN	NOM	MAX
A	0.45	0.50	0.55	0.018	0.020	0.022
A1	0.00	0.02	0.05	0.000	0.001	0.002
b	0.45	0.50	0.55	0.018	0.020	0.022
c	0.12	0.15	0.18	0.005	0.006	0.007
D	0.95	1.00	1.05	0.037	0.039	0.041
e	0.65 BSC			0.026 BSC		
E	0.55	0.60	0.65	0.022	0.024	0.026
L	0.20	0.25	0.30	0.008	0.010	0.012
h	0.07	0.12	0.17	0.003	0.005	0.007

## Suggested Land Pattern

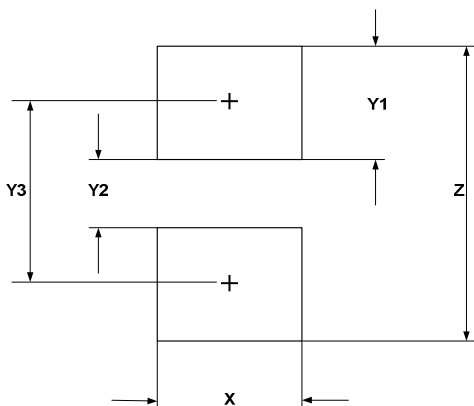

SYM	DIMENSIONS	
	MILLIMETERS	INCHES
X	0.60	0.024
Y1	0.50	0.020
Y2	0.30	0.012
Y3	0.80	0.032
Z	1.30	0.052

## Contact Information

Applied Power Microelectronics Co., Ltd.  
 Room 5A11, Chuangjie Building, 178 South Yulong Road,  
 Changzhou, Jiangsu 21300, P. R. China  
 Phone: +86 (0519) 8375 8618, Fax: +86 (0519) 8375 6618